

CLOPAY MODELS 1000, 1001, 1100, 183, 186, 187 HOLMES MODELS 52, 54

NOTE 1:
DOORS UP TO 7'-0" HIGH CONSIST OF (4) SECTIONS (NOT SHOWN)
DOORS OVER 7'-0" HIGH CONSIST OF (5) SECTIONS (SHOWN).

REVISIONS					
REV. NO.	ZONE:	DATE:	ECN NO.	APPVD:	DESCRIPTION
01	-	10/28/03	ER1022R02	SH	ADDED M/N 52, 54

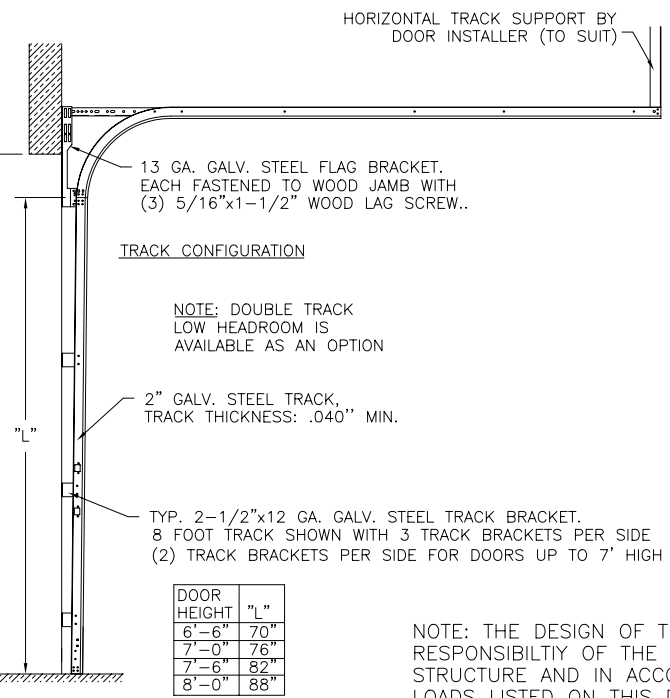
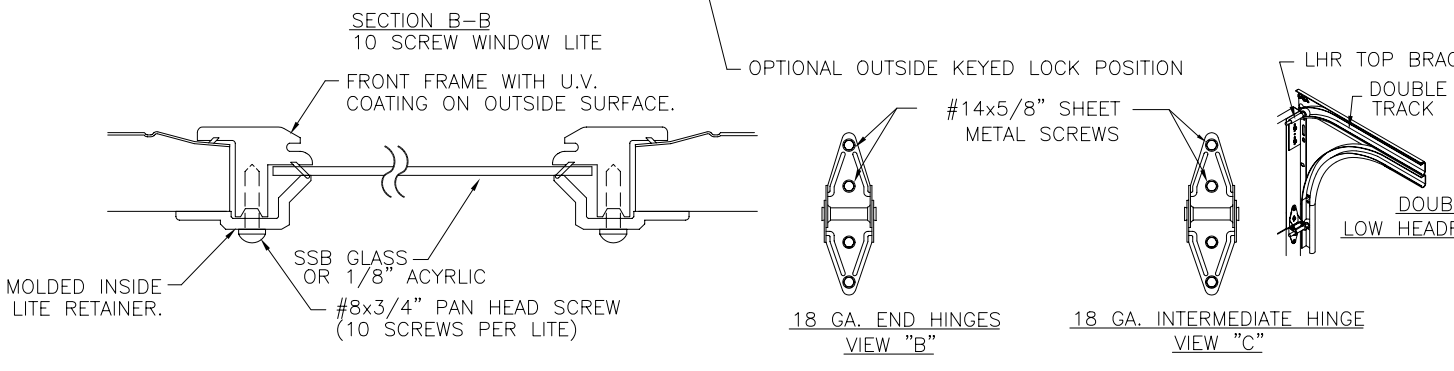
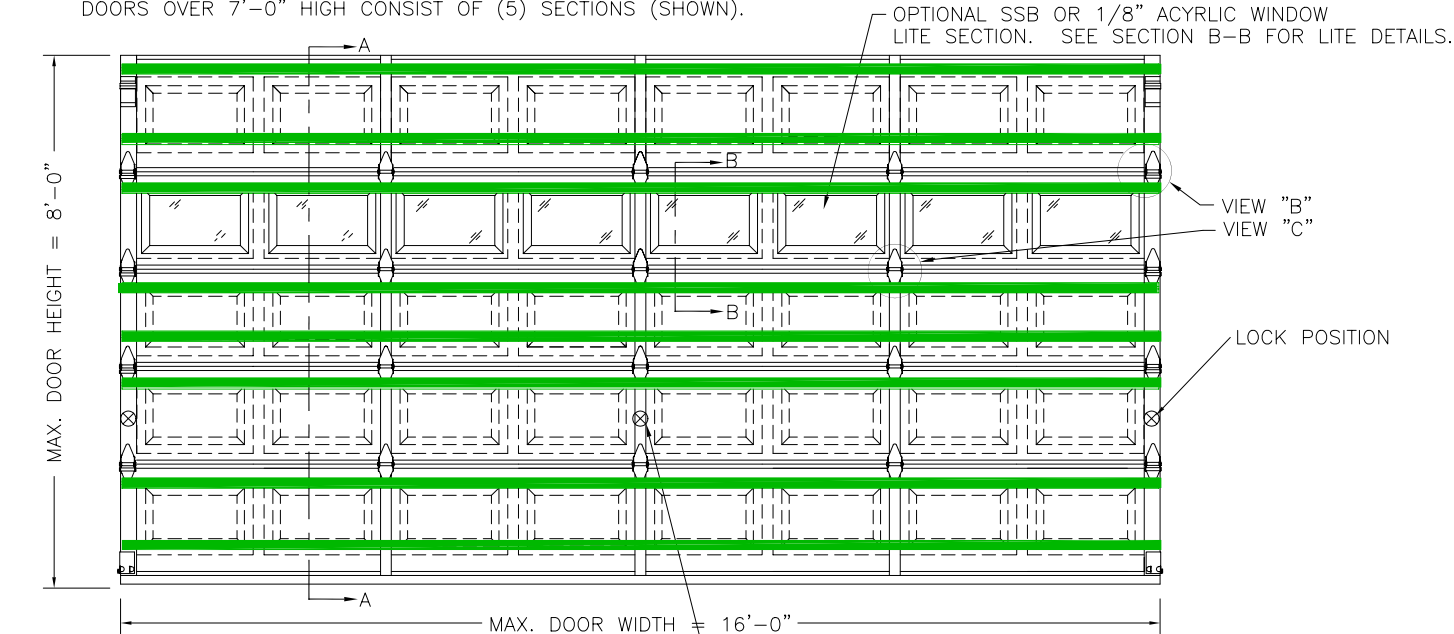

VERTICAL JAMB ATTACHMENT (WOOD FRAME BUILDINGS):
 OPTION 1: 3/8" x 3" (1-1/2" EMBED) LAG SCREWS ON 24" CENTERS. 1-1/8" O.D. MIN. WASHER REQUIRED. LAG SCREWS MAY BE COUNTERSUNK (NOT REQUIRED) TO PROVIDE FLUSH MOUNTING SURFACE.
 OPTION 2: 16D x 3-1/2" (2" EMBED) COMMON WIRE NAILS ON 8" CENTERS. (HORIZONTAL JAMBS DO NOT TRANSFER LOAD.)

DESIGN ENGINEER: MARK WESTERFIELD, P.E.
 FLORIDA P.E. #48495, NC P.E. #23832, TEXAS P.E. #91513
 DESIGN LOADS: +12.5 PSF & -14.0 PSF
 TEST LOADS: +19.0 PSF & -21.0 PSF

DOOR HEIGHT	"L"
6'-6"	70"
7'-0"	76"
7'-6"	82"
8'-0"	88"

NOTE: THE DESIGN OF THE SUPPORTING STRUCTURAL ELEMENTS SHALL BE THE RESPONSIBILITY OF THE PROFESSIONAL OF RECORD FOR THE BUILDING OR STRUCTURE AND IN ACCORDANCE WITH CURRENT BUILDING CODES FOR THE LOADS LISTED ON THIS DRAWING. PREPARATION OF JAMBS BY OTHERS.

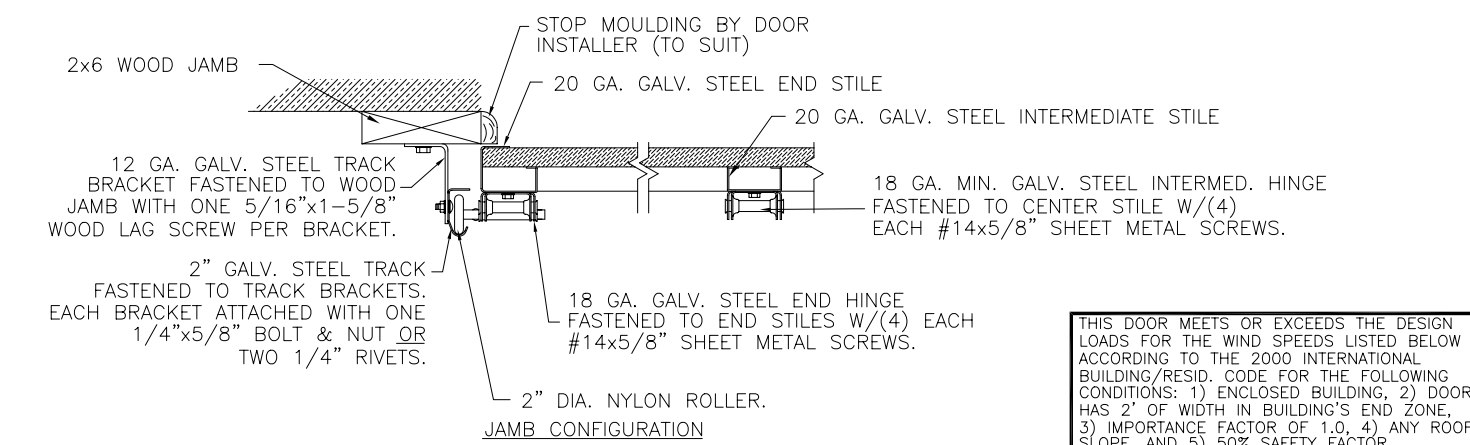

THIS DOOR MEETS OR EXCEEDS THE DESIGN LOADS FOR THE WIND SPEEDS LISTED BELOW ACCORDING TO THE 2000 INTERNATIONAL BUILDING/RESID. CODE FOR THE FOLLOWING CONDITIONS: 1) ENCLOSED BUILDING, 2) DOOR HAS 2' OF WIDTH IN BUILDING'S END ZONE, 3) IMPORTANCE FACTOR OF 1.0, 4) ANY ROOF SLOPE, AND 5) 50% SAFETY FACTOR.	
WIND SPEED (MPH)	≤ 90
EXPOSURE LEVEL	B
MEAN ROOF HEIGHT	30'

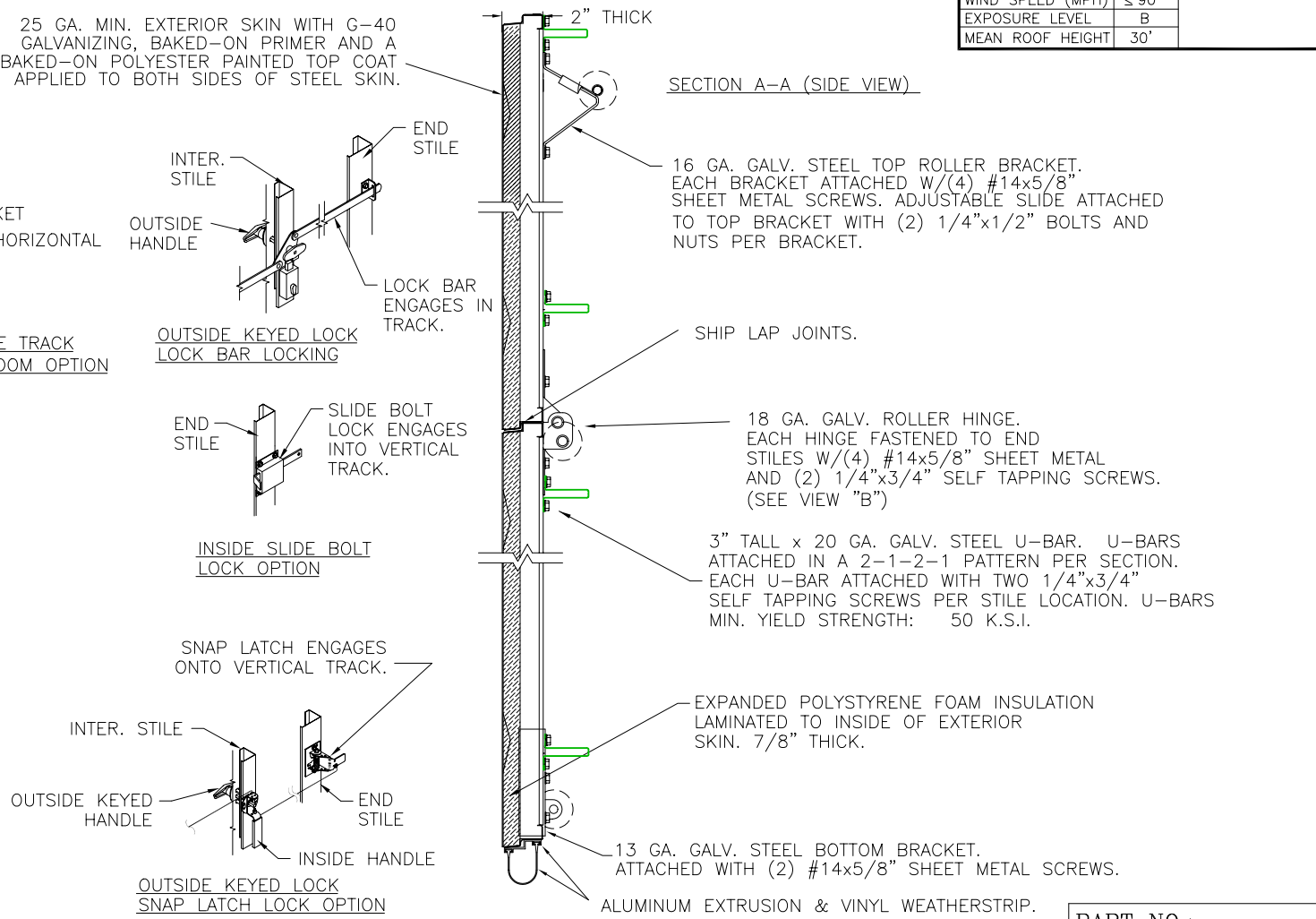

NOTICE: Confidential/Proprietary information of CLOPAY BUILDING PRODUCTS CO. is contained herein and may not be disclosed, used, duplicated, made available, or distributed without its prior consent. Failure to observe this notice may result in liability for any damages and losses resulting therefrom.

Unless Stated Otherwise TOLERANCES are:
 .0 = ± .03
 .00 = ± .015
 .000 = ± .005
 .0000 = ± .001
 Degrees = ± 1/2"

Third Angle Projection

Unless Stated Otherwise DIMENSIONS ARE IN INCHES.

Glopay Building Products Company
 8585 Duke Boulevard
 Mason, OH 45040
 (513) 770-4800

PART NO.:
 DESCRIPTION: 1000/1001/1100/183/186/187 DC +12.5/-14 PSF DES.

DRAWN BY: DAS	DATE: 11/27/02	SCALE: NTS	DWG. B
CHECKED BY:	DATE:	SHEET 1 OF 1	SIZE B
DWG. NO.: 102709		REV. NO. 01	