

CLOPAY MODELS H400, H401 (24 GA. EXTERIOR SKIN)
 CLOPAY MODELS H300, H301, H310 (27 GA. MIN. EXTERIOR SKIN)

REVISIONS

REV. NO.	ZONE:	DATE:	ECN NO.	APPVD:	DESCRIPTION
00	-	4/25/03	ER1022	SH	ORIGINAL ISSUE

THIS DOOR MEETS OR EXCEEDS THE DESIGN LOADS FOR THE WIND SPEEDS LISTED BELOW ACCORDING TO THE 2000 INTERNATIONAL BUILDING/RESID. CODE FOR THE FOLLOWING CONDITIONS: 1) ENCLOSED BUILDING, 2) DOOR HAS 2' OF WIDTH IN BUILDING'S END ZONE, 3) IMPORTANCE FACTOR OF 1.0, 4) ANY ROOF SLOPE, AND 5) 50% SAFETY FACTOR.

WIND SPEED (MPH)	≤ 90
EXPOSURE LEVEL	B
MEAN ROOF HEIGHT	30'

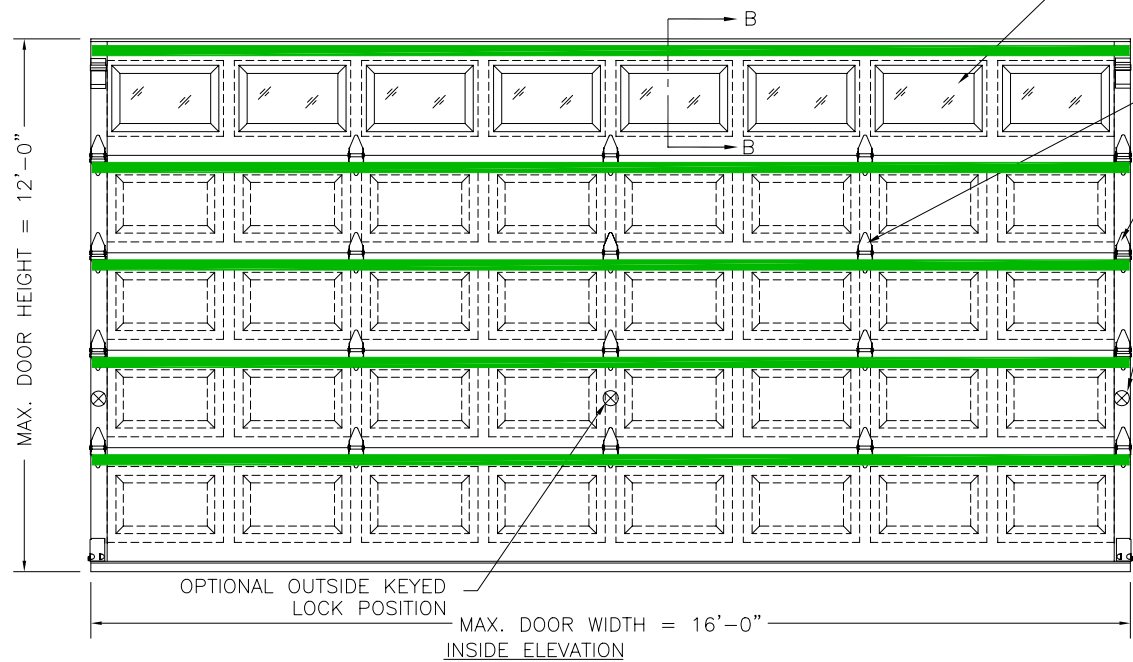

OPTIONAL WINDOW LITES AVAILABLE IN ALL MODELS. (SEE SECTION B-B)

SEE INTERMEDIATE HINGE DETAIL

SEE END HINGE DETAIL

LOCK POSITION

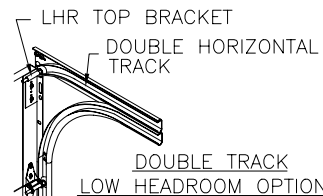

DOOR HEIGHT	# OF SECTIONS
8'-3" TO 8'-9"	5
9'-0" TO 10'-6"	6
10'-9" TO 12'-0"	7

27 GA. MIN. STEEL EXTERIOR GALV. SKIN WITH A BAKED-ON PRIMER AND A BAKED-ON POLYESTER PAINTED TOP COAT.

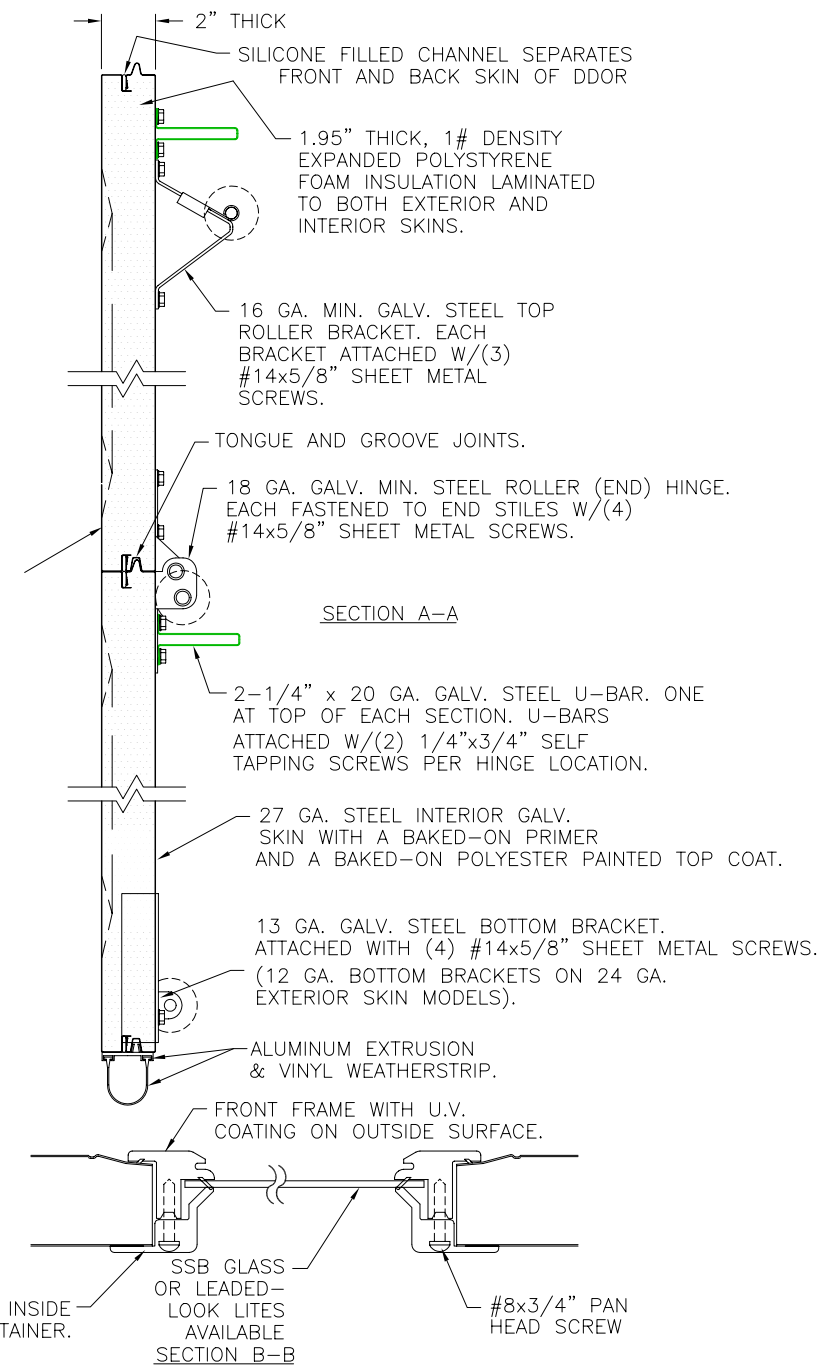

DESIGN ENGINEER: MARK WESTERFIELD, P.E.
 FLORIDA P.E. #48495, NC P.E. #23832, TEXAS P.E. #91513

VERTICAL JAMB ATTACHMENT (WOOD FRAME BUILDINGS):
 OPTION 1: 3/8" x 3" (1-1/2" EMBED) LAG SCREWS ON 24" CENTERS. 1-1/8" O.D. MIN. WASHER REQUIRED. LAG SCREWS MAY BE COUNTERSUNK (NOT REQUIRED) TO PROVIDE FLUSH MOUNTING SURFACE.
 OPTION 2: 16D x 3-1/2" (2" EMBED) COMMON WIRE NAILS ON 8" CENTERS. (HORIZONTAL JAMBS DO NOT TRANSFER LOAD.)

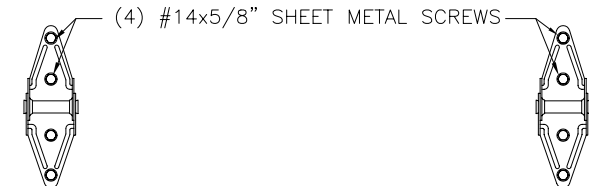
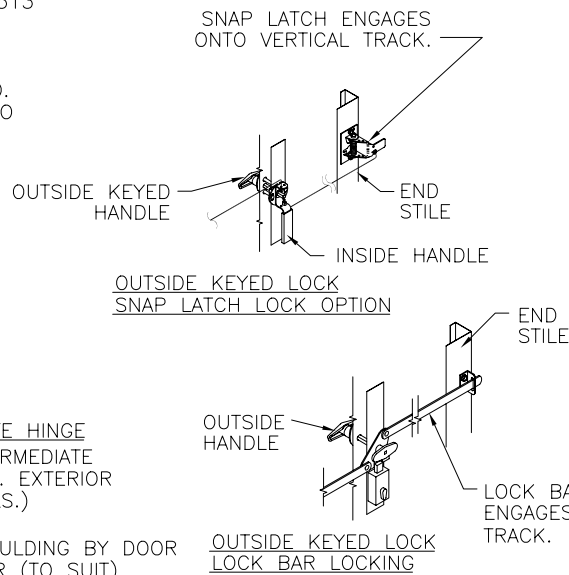

18 GA. END HINGE
 (NOTE: 14 GA. END HINGES ON 24 GA. EXTERIOR SKIN DOOR MODELS.)

18 GA. INTERMEDIATE HINGE
 (NOTE: 14 GA. INTERMEDIATE HINGES ON 24 GA. EXTERIOR SKIN DOOR MODELS.)

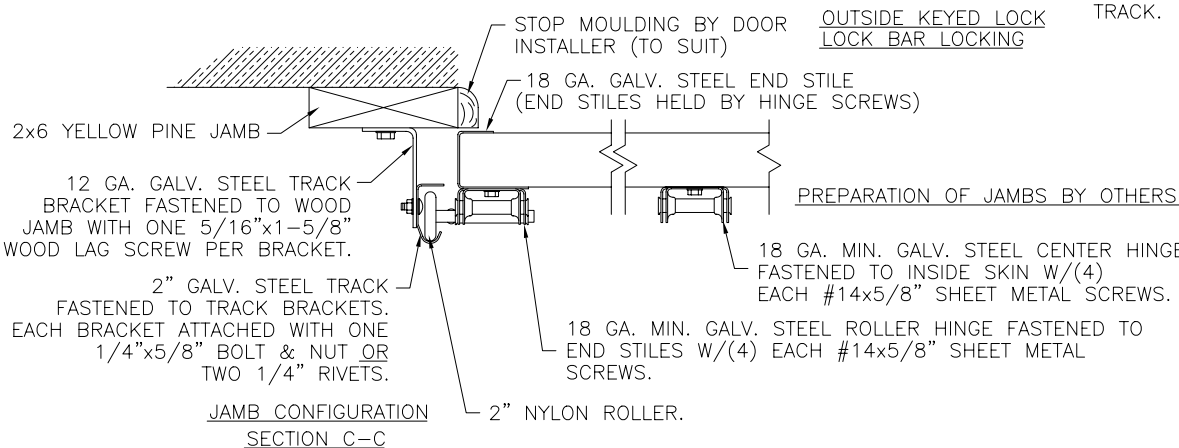

JAMB CONFIGURATION SECTION C-C

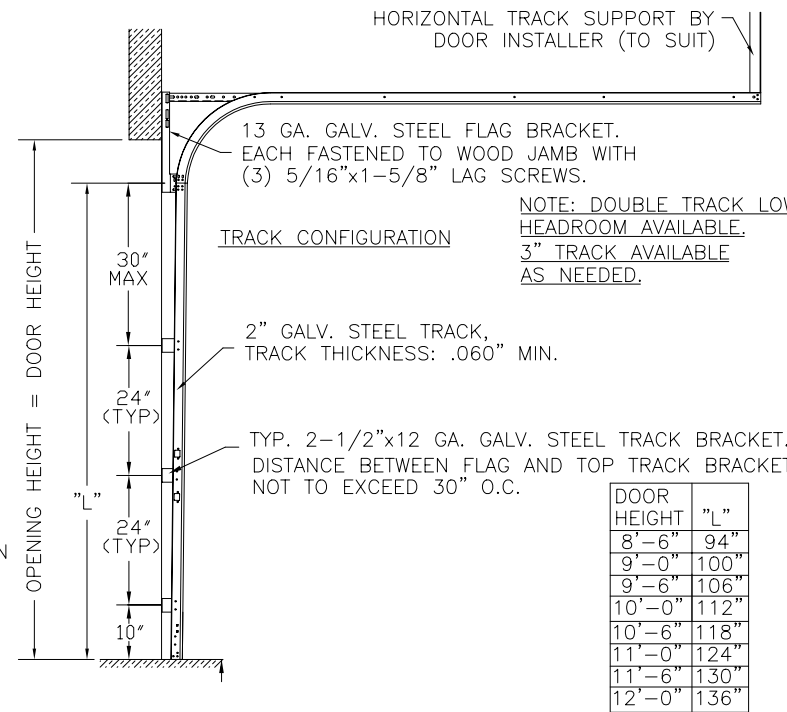

NOTE: THE DESIGN OF THE SUPPORTING STRUCTURAL ELEMENTS SHALL BE THE RESPONSIBILITY OF THE PROFESSIONAL OF RECORD FOR THE BUILDING OR STRUCTURE AND IN ACCORDANCE WITH CURRENT BUILDING CODES FOR THE LOADS LISTED ON THIS DRAWING.

DOOR HEIGHT	"L"
8'-6"	94"
9'-0"	100"
9'-6"	106"
10'-0"	112"
10'-6"	118"
11'-0"	124"
11'-6"	130"
12'-0"	136"

DESIGN LOADS: +12.5 PSF & -14.0 PSF
 TEST LOADS: +19.0 PSF & -21.0 PSF

NOTICE: Confidential/Proprietary information of CLOPAY BUILDING PRODUCTS CO. is contained herein and may not be disclosed, used, duplicated, made available, or distributed without its prior consent. Failure to observe this notice may result in liability for any damages and losses resulting therefrom.

Unless Stated Otherwise TOLERANCES are
 .0 = ±.03
 .00 = ±.015
 .000 = ±.005
 .0000 = ±.001
 Degrees = ±1/2'

Glopay Building Products Company
 8585 Duke Boulevard
 Mason, OH 45040
 Tel. No. 1-513-381-4800
 Fax No. 1-513-762-3519

DESCRIPTION: H400/H401/H310/H300/H301 DC +12.5/-14.0 PSF DES.

DRAWN BY: DAS DATE: 11/22/02 SCALE: NTS DWG. B
 CHECKED BY: DATE: SHEET 1 OF 1 SIZE B
 DWG. NO.: 102713 REV. NO. 00



Unless Stated Otherwise DIMENSIONS ARE IN INCHES.