

CLOPAY MODELS H050, H051, H053

DOOR HEIGHT	# OF SECTIONS
8'-3" TO 8'-9"	5
9'-0" TO 10'-6"	6
10'-9" TO 12'-0"	7

REVISIONS					
REV. NO.	ZONE:	DATE:	ECN NO.	APPVD:	DESCRIPTION
00	-	10/27/03	ER1022R02	SH	ORIGINAL ISSUE

THIS DOOR MEETS OR EXCEEDS THE DESIGN LOADS FOR THE WIND SPEEDS LISTED BELOW ACCORDING TO THE 2000 INTERNATIONAL BUILDING/RESID. CODE FOR THE FOLLOWING CONDITIONS: 1) ENCLOSED BUILDING, 2) DOOR HAS 2' OF WIDTH IN BUILDING'S END ZONE, 3) IMPORTANCE FACTOR OF 1.0, 4) ANY ROOF SLOPE, AND 5) 50% SAFETY FACTOR.

WIND SPEED (MPH)	≤ 90
EXPOSURE LEVEL	B
MEAN ROOF HEIGHT	30'

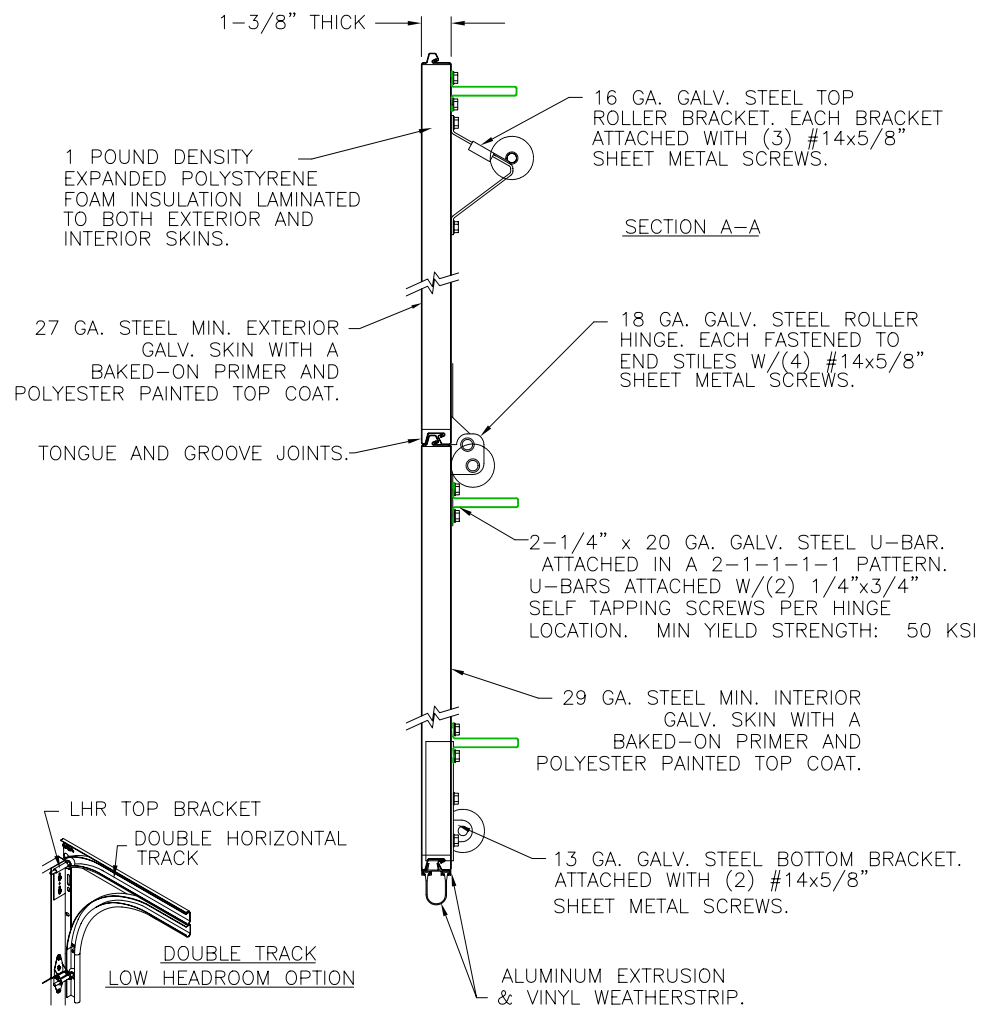
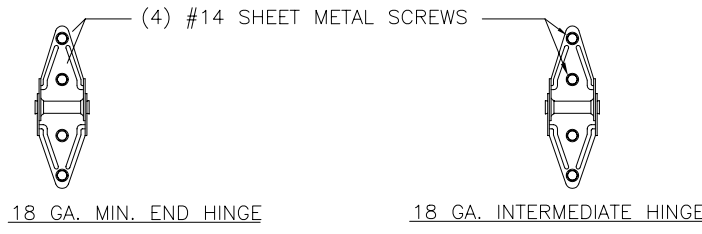
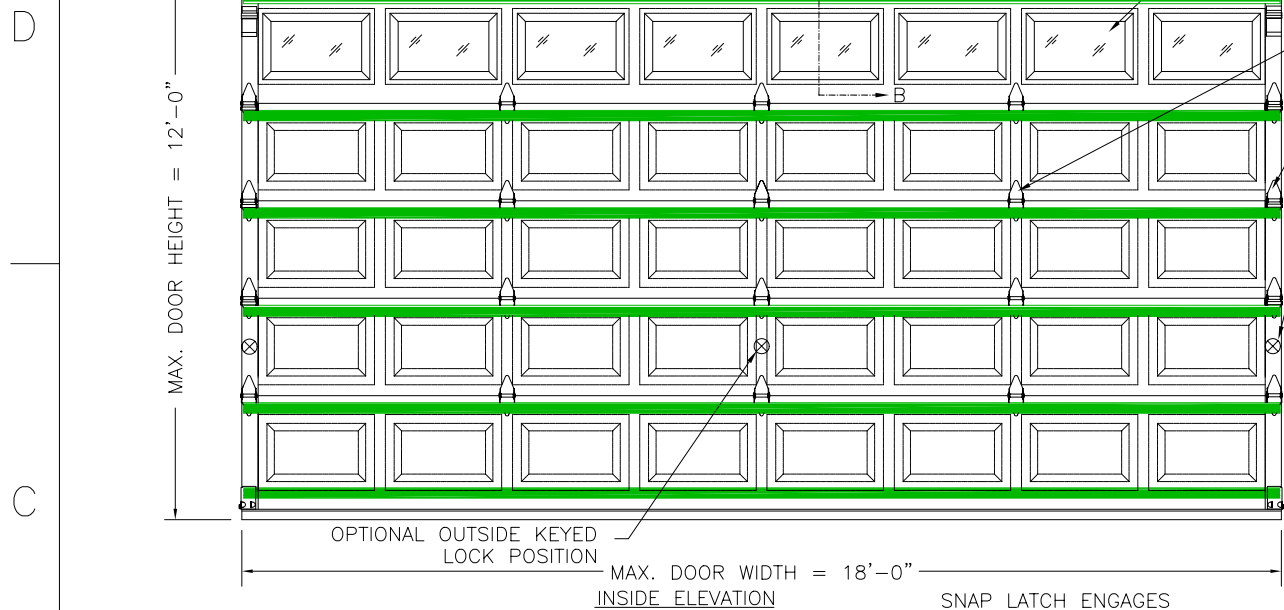

DESIGN ENGINEER: MARK WESTERFIELD, P.E.
FLORIDA P.E. #48495, NC P.E. #23832, TEXAS P.E. #91513

VERTICAL JAMB ATTACHMENT (WOOD FRAME BUILDINGS):
OPTION 1: 3/8" x 3" (1-1/2" EMBED) LAG SCREWS ON 24" CENTERS. 1-1/8" O.D. MIN. WASHER REQUIRED. LAG SCREWS MAY BE COUNTERSUNK (NOT REQUIRED) TO PROVIDE FLUSH MOUNTING SURFACE.
OPTION 2: 16D x 3-1/2" (2" EMBED) COMMON WIRE NAILS ON 7" CENTERS.
 (HORIZONTAL JAMBS DO NOT TRANSFER LOAD.)

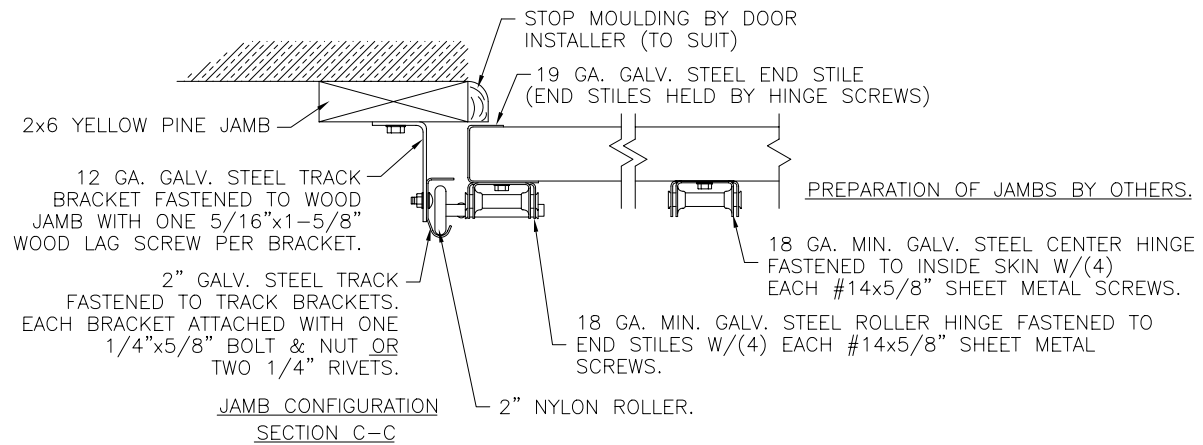
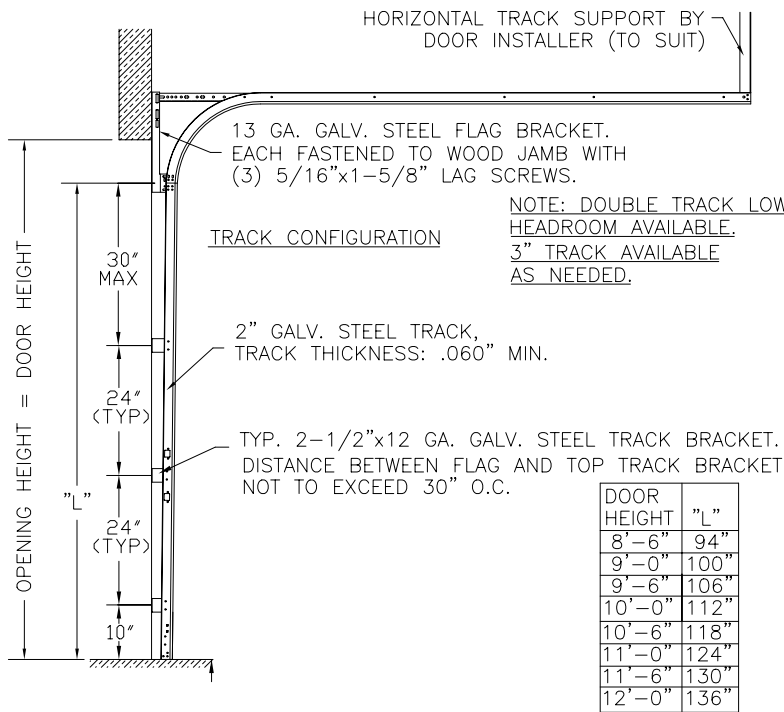
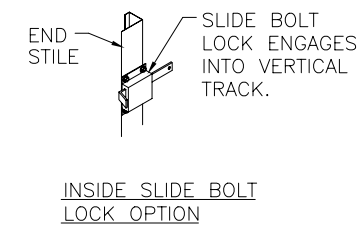
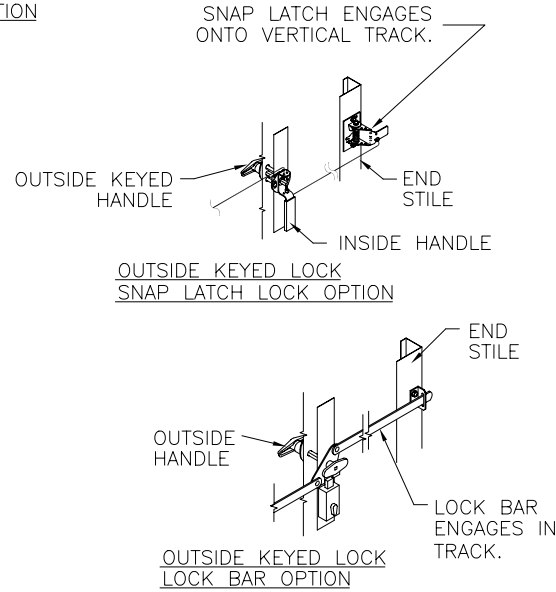

NOTE: THE DESIGN OF THE SUPPORTING STRUCTURAL ELEMENTS SHALL BE THE RESPONSIBILITY OF THE PROFESSIONAL OF RECORD FOR THE BUILDING OR STRUCTURE AND IN ACCORDANCE WITH CURRENT BUILDING CODES FOR THE LOADS LISTED ON THIS DRAWING.

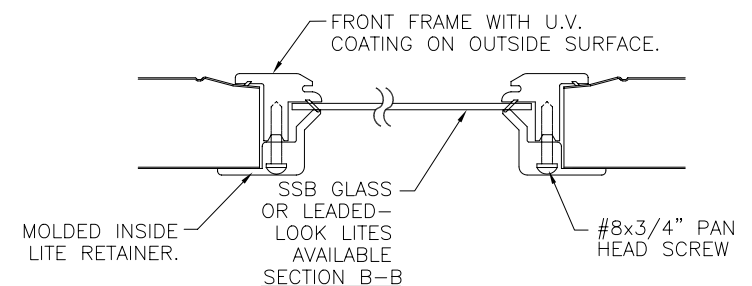

DESIGN LOADS: +12.5 PSF & -14.0 PSF
TEST LOADS: +19.0 PSF & -21.0 PSF

NOTICE: Confidential/Proprietary information of CLOPAY BUILDING PRODUCTS CO. is contained herein and may not be disclosed, used, duplicated, made available, or distributed without its prior consent. Failure to observe this notice may result in liability for any damages and losses resulting therefrom.

Unless Stated Otherwise TOLERANCES are:
 .0 = ±.03
 .00 = ±.015
 .000 = ±.005
 .0000 = ±.001
 Degrees = ± 1/2"

Third Angle Projection

Unless Stated Otherwise DIMENSIONS ARE IN INCHES.

Glopay 8585 Duke Boulevard
Mason, OH 45040
Tel. No. 1-513-381-4800
Building Products Company Fax No. 1-513-762-3519

DESCRIPTION: H050/H051/H053 18'W +12.5/-14.0 PSF DES.

DRAWN BY: RJK	DATE: 7/31/03	SCALE: NTS	DWG. B
CHECKED BY:	DATE:	SHEET 1 OF 1	SIZE
DWG. NO.: 102922		REV. NO. 00	