

CLOPAY MODELS 1000, 1001, 183, 187 HOLMES MODEL 52

| REVISIONS | | | | | |
|-----------|-------|----------|-----------|--------|----------------|
| REV. NO. | ZONE: | DATE: | ECN NO. | APPVD: | DESCRIPTION |
| 00 | - | 10/28/03 | ER1022R02 | SH | ORIGINAL ISSUE |

D
C
B
A

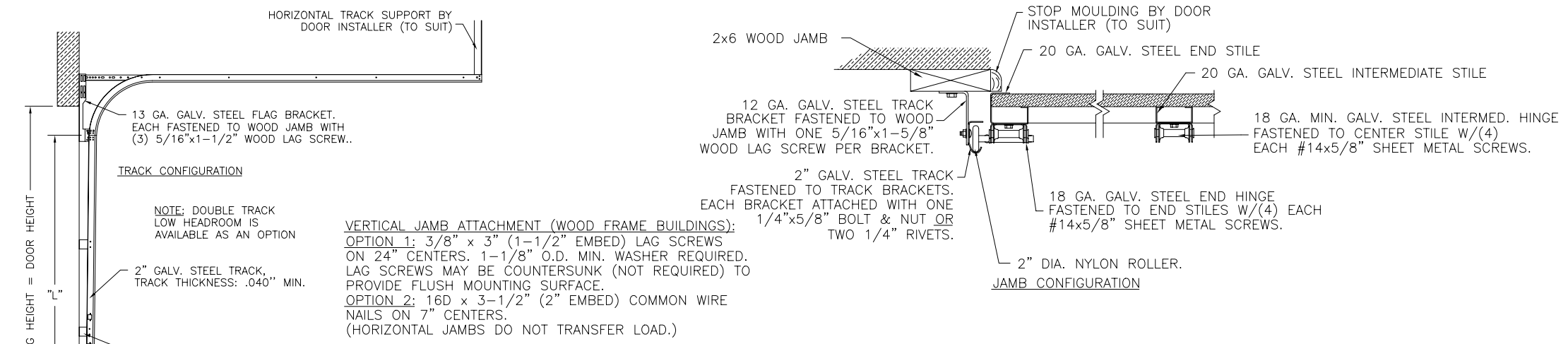
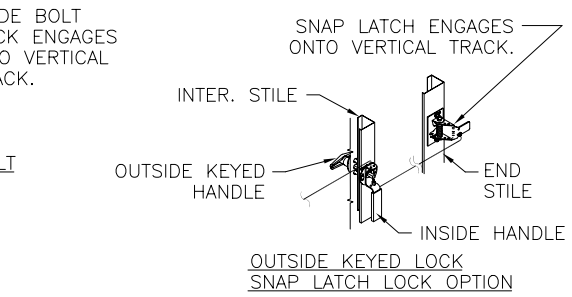
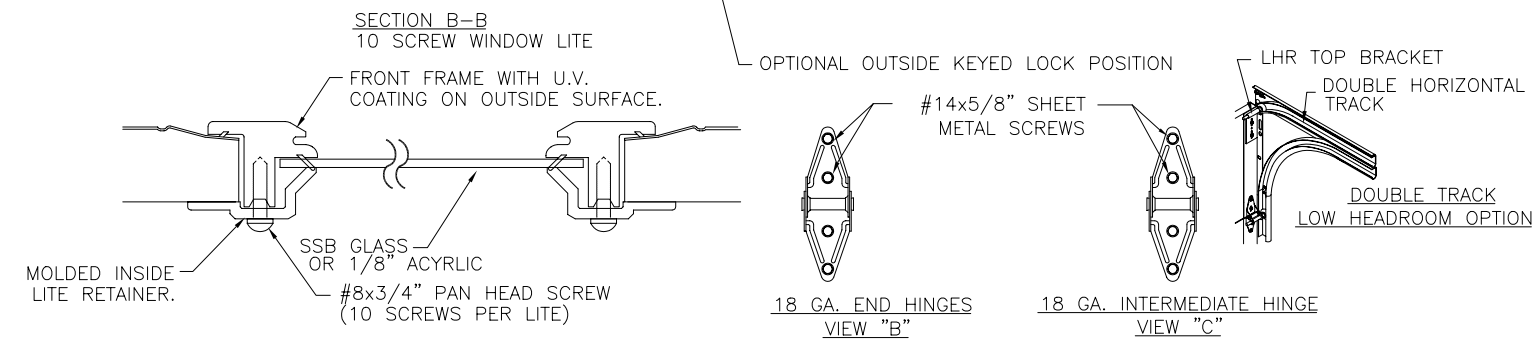
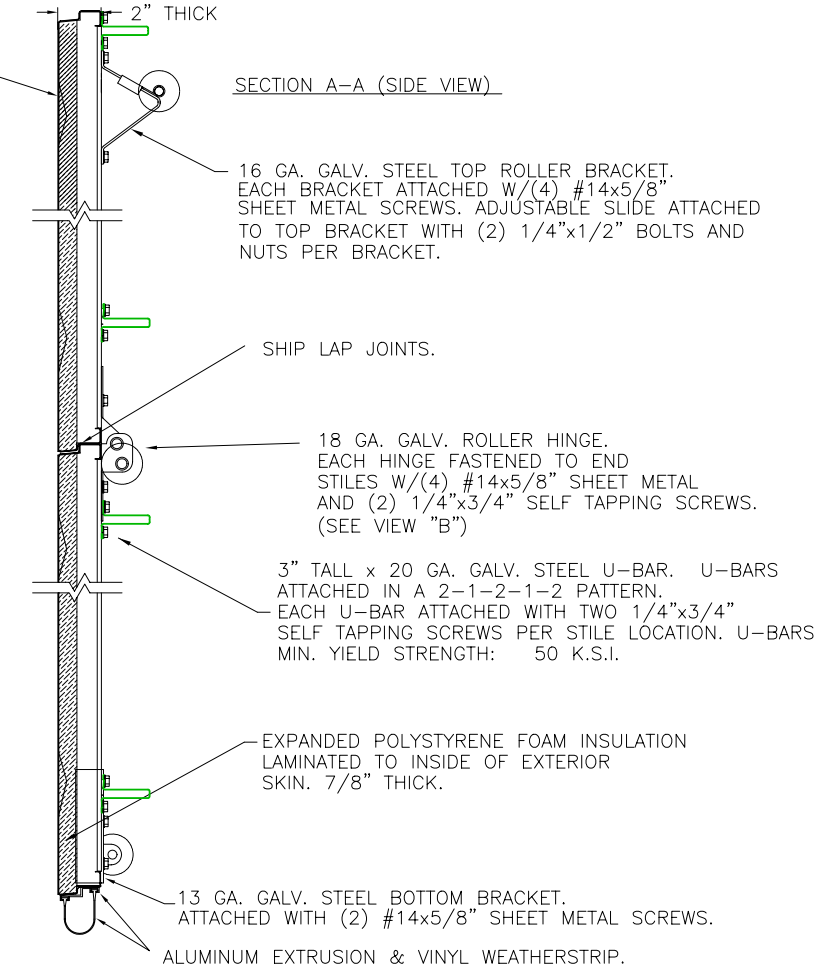
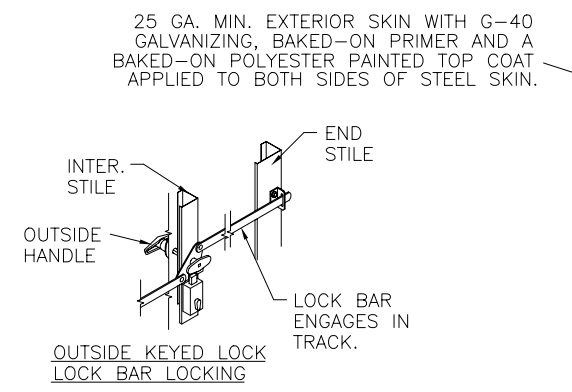
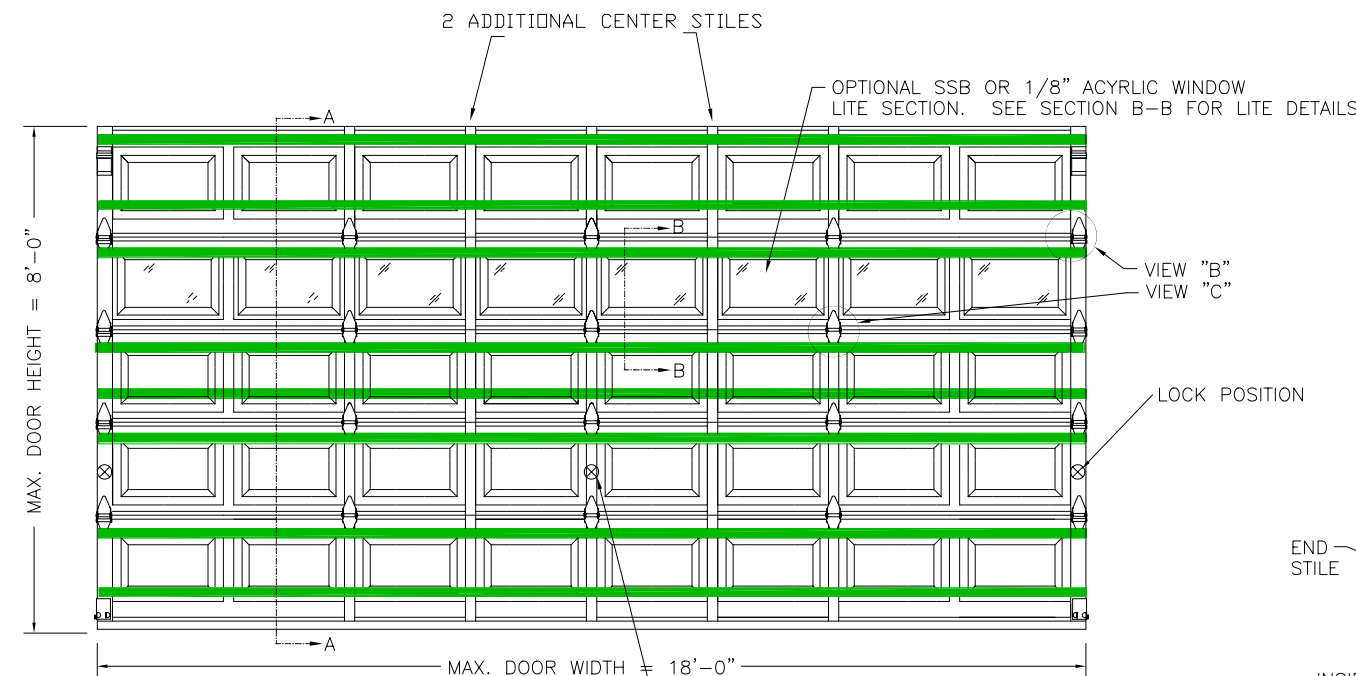

THIS DOOR MEETS OR EXCEEDS THE DESIGN LOADS FOR THE WIND SPEEDS LISTED BELOW ACCORDING TO THE 2000 INTERNATIONAL BUILDING/RESID. CODE FOR THE FOLLOWING CONDITIONS: 1) ENCLOSED BUILDING, 2) DOOR HAS 2' OF WIDTH IN BUILDING'S END ZONE, 3) IMPORTANCE FACTOR OF 1.0, 4) ANY ROOF SLOPE, AND 5) 50% SAFETY FACTOR.

| | |
|------------------|------|
| WIND SPEED (MPH) | ≤ 90 |
| EXPOSURE LEVEL | B |
| MEAN ROOF HEIGHT | 30' |

DESIGN ENGINEER: MARK WESTERFIELD, P.E.
FLORIDA P.E. #48495, NC P.E. #23832, TEXAS P.E. #91513
DESIGN LOADS: +12.5 PSF & -14.0 PSF
TEST LOADS: +19.0 PSF & -21.0 PSF

| DOOR HEIGHT | "L" |
|-------------|-----|
| 6'-6" | 70" |
| 7'-0" | 76" |
| 7'-6" | 82" |
| 8'-0" | 88" |

NOTE: THE DESIGN OF THE SUPPORTING STRUCTURAL ELEMENTS SHALL BE THE RESPONSIBILITY OF THE PROFESSIONAL OF RECORD FOR THE BUILDING OR STRUCTURE AND IN ACCORDANCE WITH CURRENT BUILDING CODES FOR THE LOADS LISTED ON THIS DRAWING. PREPARATION OF JAMBS BY OTHERS.

NOTICE: Confidential/Proprietary information of CLOPAY BUILDING PRODUCTS CO. is contained herein and may not be disclosed, used, duplicated, made available, or distributed without its prior consent. Failure to observe this notice may result in liability for any damages and losses resulting therefrom.

Unless Stated Otherwise TOLERANCES are

| | |
|---------|--------|
| .0 | ± .031 |
| .00 | ± .015 |
| .000 | ± .005 |
| .0000 | ± .001 |
| Degrees | ± 1/2° |

Third Angle Projection

Unless Stated Otherwise DIMENSIONS ARE IN INCHES.

8585 Duke Boulevard
Mason, OH 45040 USA
Tel. No. 513-770-4800
Fax No. 513-770-4853

Building Products Company

DESCRIPTION: M/N 1000/1001/183/187 18'W +12.5/-14.0 PSF DES.

| | | | |
|----------------|----------------|--------------|--------|
| DRAWN BY: SEJ | DATE: 7/28/03 | SCALE: NTS | DWG. B |
| CHECKED BY: SH | DATE: 09/08/03 | SHEET 1 OF 1 | SIZE |

DWG. NO.: 102931
REV. NO. 00