

INSULATED STEEL SANDWICH DOOR - MODEL 3203/3201

08360/CLO

Buyline 0309

- 2" Insulated Thermally Broken Steel
- 24 Gauge Exterior Skin
- Raised Panel
- Sandwich Type Construction

R-Value = 9.1

U-Value = .11

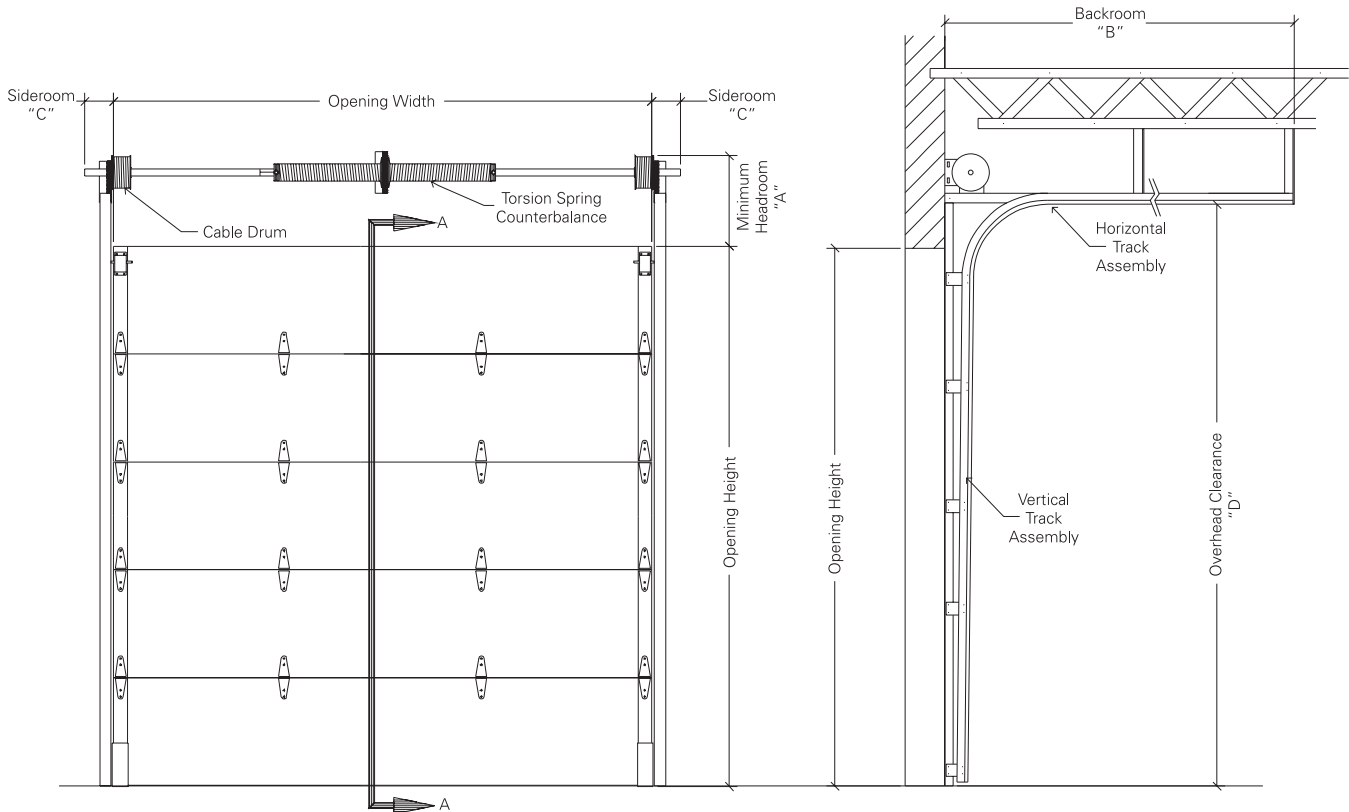

INTERIOR ELEVATION

STANDARD LIFT TRACK

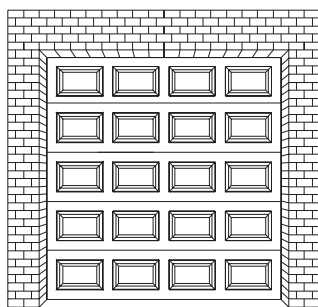

EXTERIOR ELEVATION

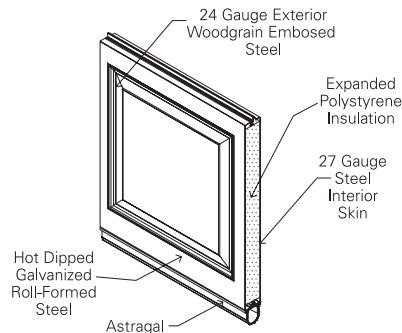

ISOMETRIC VIEW

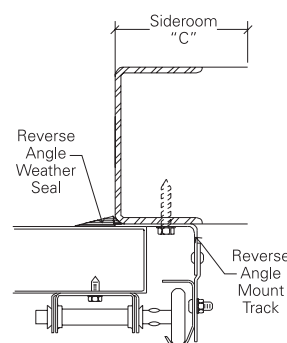

STEEL JAMB DETAIL

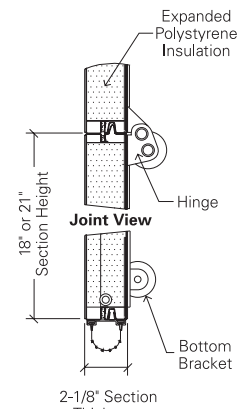

SECTION A-A
BOTTOM BRACKET VIEW



SPECIFICATIONS

PART 1 GENERAL

1.01 Section Includes

A. Upward Acting Sectional Steel Doors, including unit sections, brackets, tracks, glazing, counter balance mechanisms, and hardware.

1.02 Related Work

A. Opening preparation, miscellaneous or structural steel, finish or field painting, electrical wires, wiring, disconnect switches, conduit are in the scope of the work of other sections or trades.

B. Submit manufacturer's product data and installation instructions for each type of sectional door. Include both published data and any specific data prepared for this project.

1.03 Single Source Responsibility

A. Provide door, tracks, motors and accessories from one manufacturer for each type of door. Provide secondary components from source acceptable to manufacturer of primary components.

PART 2 PRODUCT

2.01 Manufacturer

A. Upward Acting Sectional Steel Doors are to be Clopay® Model 3203 (or 3201) as manufactured by Clopay Building Products Company, Inc.

2.02 Material/Construction

A. Type: 2" (50.80 mm) thick, sandwich construction, roll-formed commercial steel.

B. Size: Standard maximum door size is 20'2" (6.15 m) wide by 18' (5.49 m) high*. (Max 320 sq. ft.)

*Not all sizes available.

C. Section Joint: Sections to form a weather-tight tongue & groove fit.

D. Material: Hot-dipped galvanized, complying with ASTM A-924, A-653, exterior and interior skins separated by silicone filling to form thermal break and pressure bonded to an expanded polystyrene core; standard lift operating style with track and hardware; complying with DASMA 102, commercial application.

E. Finish: Pre-finished interior and exterior skins with 1-mil, three-coat baked-on polyester top coat over primer on a phosphate coating.

1. Exterior Skin: 24 gauge (.022", (.56 mm) minimum) exterior steel face sheet with woodgrain texture and raised panel design (model 3203) / Flush design (model 3201). Color: white, brown, almond, sandtone.

2. Interior Skin: 27 gauge (0.016", (.41 mm) minimum) interior steel face sheet with stucco texture. Color: white.

2.03 Related Door Components

A. End Stiles: Galvanized steel primed with white baked on polyester top coat. Attachment hardware to have pre-punched holes.

1. 18 gauge (.049", (1.25 mm) minimum) single end hinge style.

2. 16 gauge (.055", (1.40 mm) minimum) double end hinge style.

B. Hinge and Roller Assemblies: Hinges and brackets to be 14 gauge (.070", (1.78 mm) minimum) galvanized steel.

1. Ten-ball steel rollers to be full-floating ball bearing in case hardened steel cases and mounted to fit the taper of the track.

2. Hinge Support Plates: 20 gauge (.038", (.096 mm) minimum) galvanized steel. Prepunched for hinge alignment location. Tog-L-Loc™ to interior skin.

2.04 Insulation

A. 2" Expanded Polystyrene:
R-value = 9.1, U-value = .11

2.05 Tracks

A. Horizontal Track: To be 14 gauge (.075", (1.91 mm) minimum) galvanized steel reinforced with 13 gauge (.085", (2.16 mm) minimum) galvanized steel angles.

B. Rolled Galvanized Steel (select one): Standard lift track, vertical lift track, high lift track, follow-the-roof slope track, low headroom track provide: 2" (50.8 mm) or 3" (76.2 mm) as required.

C. Vertical Tracks: To be 16 gauge (.060", (1.52 mm) minimum) galvanized steel, tapered and mounted for wedge type closing.

D. Mounting: Interior face mounted on a prepared surface.

E. Track Mounting (select one):

1. Bracket Mounting: Galvanized steel mounting brackets 12 gauge (.101", (2.57 mm) minimum) thick for wood jambs.

2. Continuous or Reverse Galvanized Steel Angle Mounting: 12 gauge (.101", (2.57 mm) minimum) angle for steel jambs; splice plates 12 gauge (.101", (2.57 mm) minimum).

2.06 Spring Counterbalance

A. Springs: Shall be torsion type, low stress, helically wound, oil-tempered spring on a galvanized steel tube or solid steel shaft. Wire to provide 10,000 cycles minimum.

1. 25,000 cycles

2. 50,000 cycles

3. 100,000 cycles

B. Cable Drums: Die cast aluminum.

C. Cable: Pre-formed galvanized steel aircraft cable to provide a minimum of a 7:1 safety factor.

2.07 Operation

A. Operation Shall Be: Manual push-up, chain hoist, motor operated.

B. For Manual Operation: Requiring maximum exertion of the greater of 5% of door weight or 25 lbs. (111.2 N) force to open. Use pull rope supplied.

C. Inside and outside 3" (76.2 mm) step plate/lift handle.

2.08 Weatherstripping

A. Field-Installed Section Joint Seal Tape: Neoprene foam seal, one-piece full length between joint of sections.

B. Field Installed Jamb/Header Weatherstripping: Extruded vinyl, placed in moderate contact with outside of door sections.

2.09 Bottom Sections

A. Astragal Retainer: Full length, .040" (1.02 mm) aluminum.

B. Astragal: U-shaped flexible PVC vinyl.

C. Handle: To be located on second section.

D. Step Plate: 3" (76.2 mm) galvanized steel step plate to be located on bottom section.

2.10 Locking

A. Inside spring loaded slide bolt lock on end stile to securely engage slot in track.

1. Optional - Outside keyed five pin cylinder lock with outside key and inside lock for engaging slot in track.

2.11 Options

A. Removable Mullions: 2" (50.8 mm) carry-away or roll-away up to 14' (4.267 m) high. Swing-up available for 2" or 3" track, consult factory.

B. Glazing:

1. Window Size: 19 1/2" x 12" (495 mm x 305 mm).

2. Frame to be Cellular PVC construction.

3. Glass Available (select one):

a. 1/8" DSB

b. 1/8" Plexiglass

c. 1/2" Insulated glass

PART 3 EXECUTION

3.01 Examination

A. Verify that dimensions are correct and project conditions are suitable for installation. Do not proceed with installation until unsatisfactory conditions have been corrected.

3.02 Installation

A. Installation: To be by an authorized Clopay representative and in accordance with manufacturer's instructions and standards.

B. Submit manufacturer's product data and installation instructions for each type of sectional upward acting door. Include both published data and any specific data prepared for this project.