

Installation Instructions

W1 WINDCODE[®] Supplemental Instructions

(For use with Insulated and Uninsulated Steel Residential Garage Door Instruction Manual)

Things to Know Before You Begin

To obtain a drawing for your door, visit:

<http://www.clopaydoor.com/windcode/drawings.htm>

This is a supplement to the “Steel Residential Garage Door Instructions,” “Insulated Steel Residential Garage Door Instructions,” or “Wood Door Residential Garage Door Instructions”. All will be referred to as MANUAL. These supplemental instructions cover important information unique to WINDCODE[®] Doors. For all other information and safety warnings concerning your WINDCODE[®] garage door, see the MANUAL. Read all of the information below before beginning.

WINDCODE[®] garage doors not installed with the proper reinforcement (struts, hinges, jamb brackets, track, fasteners) will not perform as designed to meet building code requirements.

An electric or pneumatic impact gun is strongly recommended for installation of WINDCODE[®] Doors.

WINDCODE[®] Door Models have three different reinforcement configurations:

- Up to 9’0” wide
- 9’2” to 16’0” wide
- 16’2” to 18’0” wide

To determine what door you have, locate the identification sticker found on the end of the door package (See Fig. 1). This sticker will identify the door size, door model, and WINDCODE[®] rating. **Note: It is the buyer’s responsibility to purchase the garage door required to meet local building codes.**

These instructions cover the following hardware attachment:

- 1) Addition of Struts
- 2) Jamb Configuration & Attachment
- 3) Opener Reinforcement

Place the enclosed WINDCODE[®] sticker on the inside bottom section of your door. This sticker may help eliminate questions during building inspection.

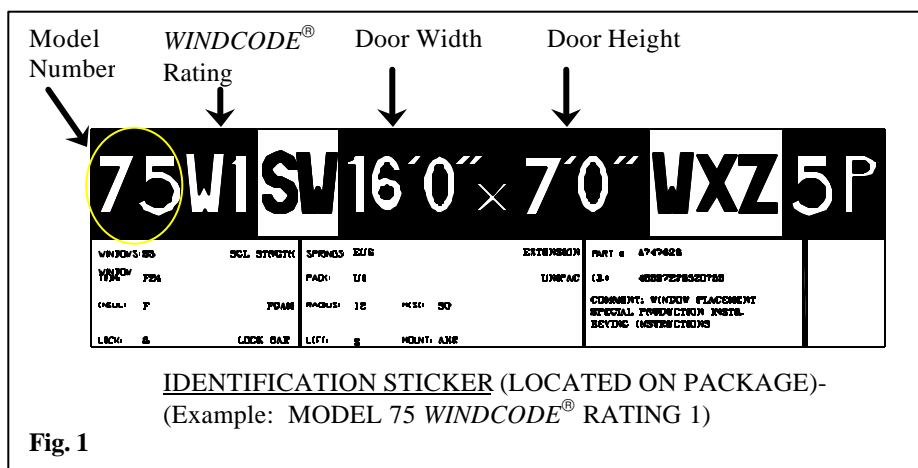

Strut Attachment

Struts are placed lengthwise across the door to add strength. Strut configurations vary depending on *WINDCODE*[®] rating and door size. Table 1 shows *WINDCODE*[®] Doors and the corresponding drawing number. Most strut configurations are listed in Table 1. To obtain the specified drawing, please visit www.clopaydoor.com/windcode/drawings.htm. These drawings include specific strut configuration and detailed technical information for each door. After reviewing the strut configuration you may begin installation. For strut configurations not listed in Table 1 please call the Consumer Hotline listed in your MANUAL.

Table 1:

Drawings available at www.clopaydoor.com/windcode/drawings.htm

Model Numbers	<i>WINDCODE</i> ^a Rating	Door Width	Strut Size	Strutting Configuration	Corresponding Drawing Number
Double Steel Skin Door Models					
4300, 4301, 4310, 4400, 4401, HDG, HDGL, 66, 67, 68	W1	Up to 9'0"	NA	No struts required	102694
4300, 4301, 4310, 4400, 4401, HDG, HDGL, 66, 67, 68	W1	9'2" to 16'0"	2 ¼"	See Fig. 5	102695
4300, 4301, 4310, 4400, 4401, HDG, HDGL, 66, 67, 68	W1	16'2" to 18'0"	3"	See Fig. 5	102736
H300, H301, H310, H400, H401	W1	Up to 9'0"	NA	No struts required	102712
H300, H301, H310, H400, H401	W1	9'2" to 16'0"	2 ¼"	See Fig. 5	102713
H300, H301, H310, H400, H401	W1	16'2" to 18'0"	3"	See Fig. 5	102760
2050, 2051, 4050, 4051, 4053, 62, 64, 65, 62LG	W1	Up to 9'0"	2 ¼"	Refer to Drawing on Website	102714
2050, 2051, 4050, 4051, 4053, 62, 64, 65, 62LG	W1	9'2" to 16'0"	2 ¼"	See Fig. 6	102715
2050, 2051, 4050, 4051, 4053, 62, 64, 65, 62LG	W1	16'2" to 18'0"	3"	See Fig. 7	102867
H050, H051, H053	W1	Up to 9'0"	2 ¼"	Refer to Drawing on Website	102716
H050, H051, H053	W1	9'2" to 16'0"	2 ¼"	See Fig. 6	102717
H050, H051, H053	W1	16'2" to 18'0"	2 ¼"	See Fig. 7	102922
Single Steel Skin Door Models					
73, 75, 75L, 76, 84A, 94, 1500, 42, 46, 48	W1	Up to 9'0"	2 ¼"	See Fig. 9	102738
73, 75, 75L, 76, 84A, 94, 1500, 42, 46, 48	W1	9'2" to 16'0"	3"	See Fig. 7	102739
73, 75, 84A, 94, 1500, 42, 48	W1	16'2" to 18'0"	3"	See Fig. 6	102933
H73, H76, H94, H500	W1	Up to 9'0"	2 ¼"	See Fig. 9	102740
H73, H76, H94, H500	W1	9'2" to 16'0"	3"	See Fig. 7	102741
H76, H94, H500	W1	16'2" to 18'0"	3"	See Fig. 6	102972
1000, 1001, 1100, 183, 186, 187, 52, 54, 52LS	W1	Up to 9'0"	2 ¼"	See Fig. 8	102708
1000, 1001, 1100, 183, 186, 187, 52, 54, 52LS	W1	9'2" to 16'0"	3"	See Fig. 6	102709
1000, 1001, 183, 187, 52, 52LS	W1	16'2" to 18'0"	3"	See Fig. 6	102931
H000, H001, H100	W1	Up to 9'0"	2 ¼"	See Fig. 8	102710
H000, H001, H100	W1	9'2" to 16'0"	3"	See Fig. 6	102711
H000, H001	W1	16'2" to 18'0"	3"	See Fig. 6	102954
251S, 251L, 251F, B178, B278, B378, 55S, 55L, S51S, S51L, S51F	W1	Up to 9'0"	2 ¼"	See Fig. 5	102935
251S, 251L, 251F, B178, B278, B378, 55S, 55L, S51S, S51L, S51F	W1	9'2" to 16'0"	3"	See Fig. 6	102937
251S, 251F, B178, B378, 55S, S51S, S51F	W1	16'2" to 18'0"	3"	See Fig. 6	102939
150S, C125, 150L, C225, 140S, C124, 140L, 45S, 45L, B5S, B5L, B4F, 44S, B4S, B4L	W1	Up to 9'0"	2 ¼"	See Fig. 5	102942
150S, C125, 150L, C225, 140S, C124, 140L, 45S, 45L, B5S, B5L, B4F, 44S, B4S, B4L	W1	9'2" to 16'0"	3"	See Fig. 6	102944
150S, C125, 140S, C124, 45S, B5S, B4F, 44S, B4S	W1	16'2" to 18'0"	3"	See Fig. 6	102946
Wood Door Models					
RHxx, RRxx, RCxx, CHxx, CRxx, CCxx (Reserve/Carriage House Collection)	W1	Up to 9'0"	NA	No struts required	102901
RHxx, RRxx, RCxx, CHxx, CRxx, CCxx (Reserve/Carriage House Collection)	W1	9'2" to 16'0"	3"	Refer to Drawing on Website	102900

Strut Installation (See Fig 2 & Fig 3)

Depending on the type of *WINDCODE*[®] Door (double steel skin or single steel skin), there are two possible ways that a strut can be installed. For double steel skin doors, refer to Fig 2. For single steel skin doors, refer to Fig 3. For wood doors refer to the drawing located on the website. For the correct configuration and placement of struts, see Table 1 (strutting configuration) and corresponding Figure drawing on the back of this sheet. To attach strut, position the strut on the door. Drill one 9/32" hole at the top and one 9/32" hole at the bottom of the strut at all hinge and stile locations if no pre-punched holes exist. If an electric or pneumatic impact gun is being used no holes need to be drilled beforehand. Attach strut to door section with 1/4"x3/4" self-tapping screws at drilled or pre-punched holes at each hinge and stile locations.

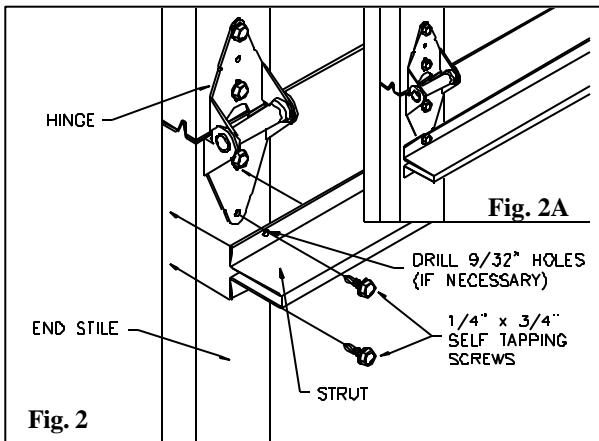

Double Steel Skin Doors

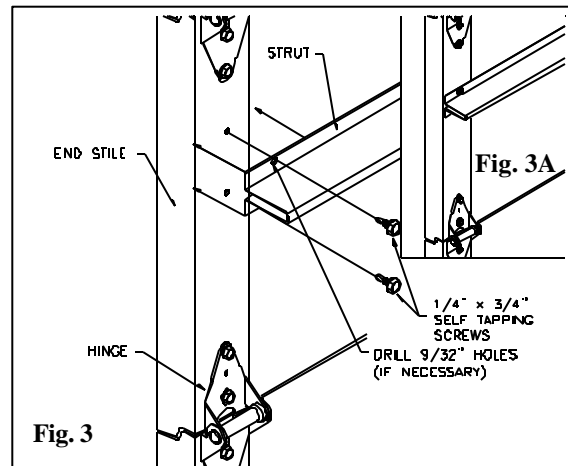

Single Steel Skin Doors

Jamb Configuration & Attachment

NOTE: The design of the supporting structural elements (i.e. framing studs) shall be the responsibility of the professional of record for the building or structure and in accordance with current building codes for the loads listed on the technical drawing for the specific model. It is also important that the vertical 2 x 6 wood jambs are attached to the supporting structure in a method that is sufficient to transfer the loads exerted by the wind pressures. Some suggested vertical jamb attachment fastening methods are included in the drawings and in Table 2. For maximum holding strength, jamb attachment fasteners should be installed in the center of the jambs. Jambs should not split or crack.

Table 2

Fastener Type	Specification	Maximum Distance Between Fasteners*		
		Up to 9'0" Wide	9'2" to 16'0" Wide	16'2" to 18'0" Wide
Lag Screw	3/8"x 3" (1- 1/2" Embedment into Framing Studs)	24"	24"	24"
Common Wire Nails	16D x 3 1/2" (2" Embedment into Framing Studs)	13"	8"	7"

*First fastener starting from bottom at no more than half of maximum distance between fasteners listed in Table 2. Highest fastener installed at least as high as the door opening. (See Fig. 4)

Opener Reinforcement

Refer to the MANUAL for installation instructions. If the *WINDCODE*[®] Door requires a strut across the top of the top section, this takes the place of any horizontal angle iron required by the MANUAL. The vertical angle as shown in the MANUAL is still required on *WINDCODE*[®] Doors.

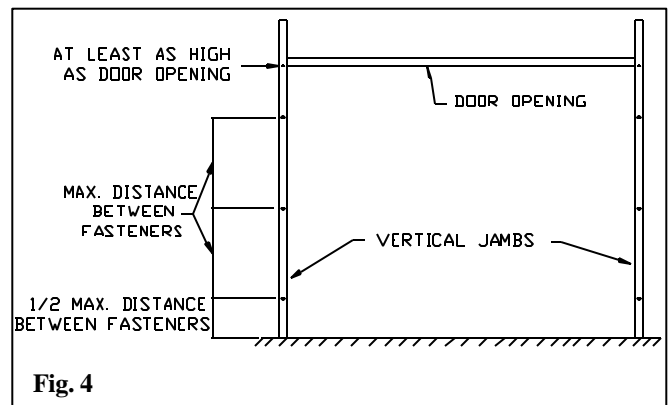
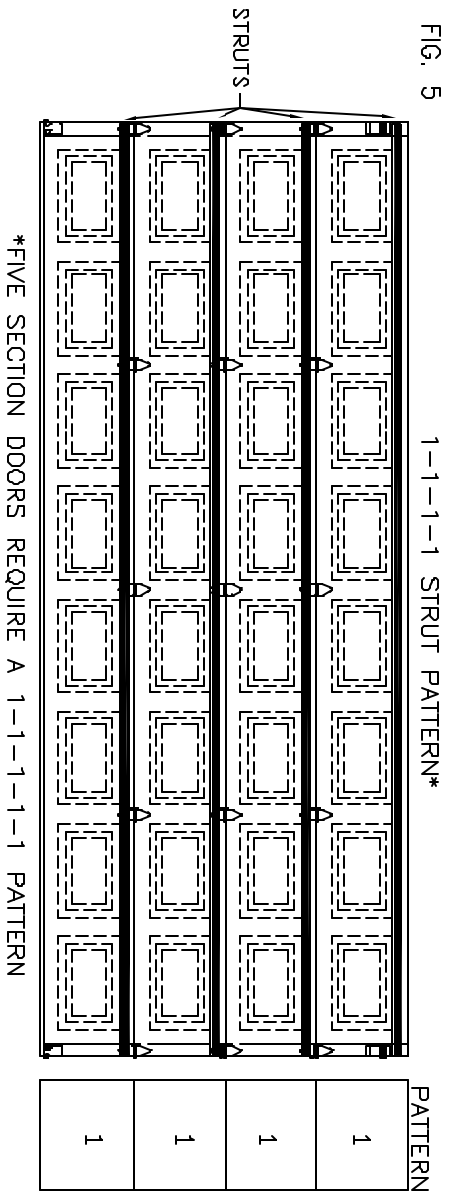

Fig. 4

FIG. 5



NOTES:

- 1) VIEW IS FROM THE INSIDE LOOKING OUT.
- 2) FOR DOORS WITH MORE THAN FIVE SECTIONS REFER TO DRAWING ON WEBSITE.
- 3) THE BOTTOM SECTION IS CONSIDERED THE FIRST SECTION, THE SECOND SECTION FROM THE BOTTOM IS THE SECOND SECTION, ETC.
- 4) STRUT PATTERN READS FROM BOTTOM OF DOOR TO TOP

FIG. 6

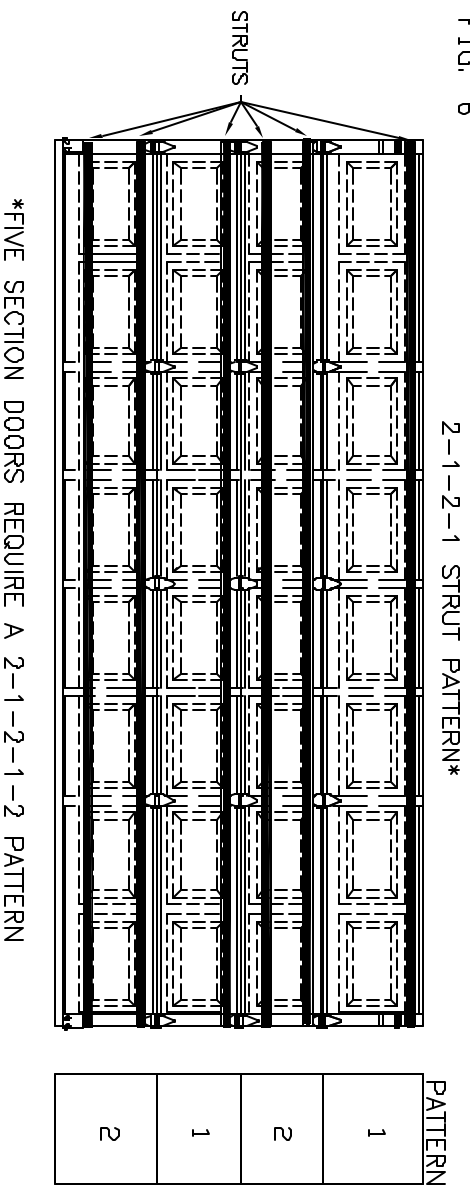

FIG. 8

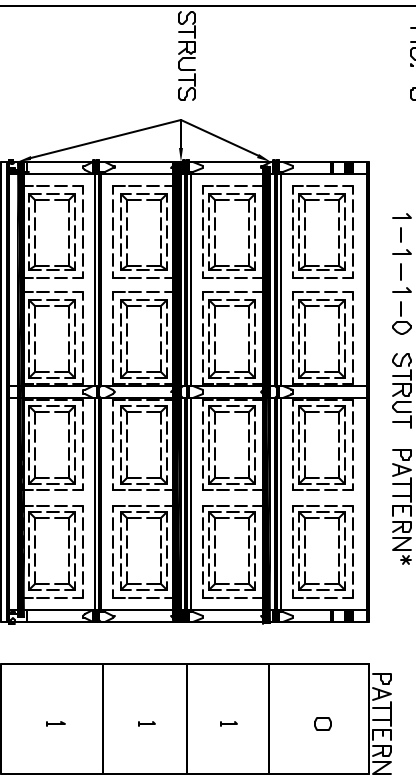

FIG. 7

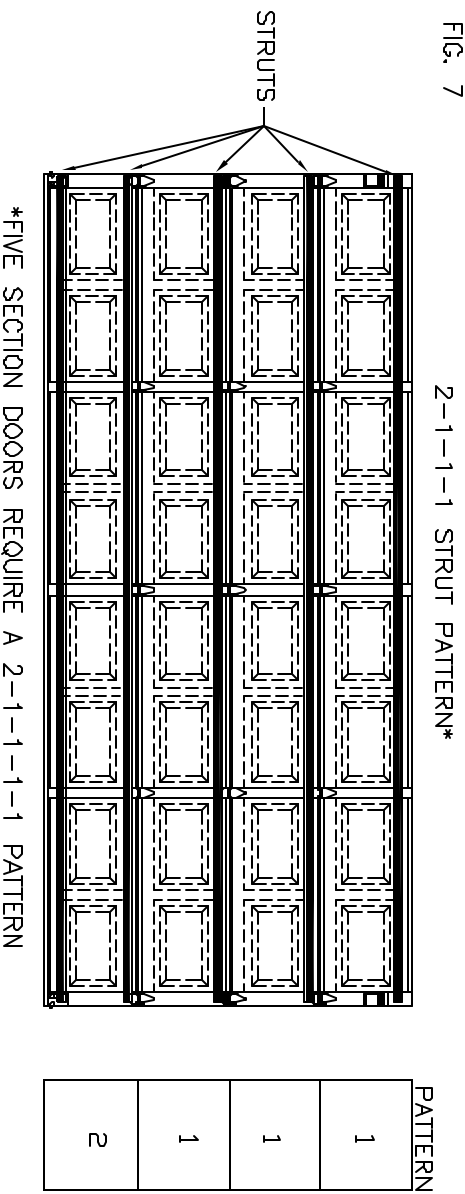

FIG. 9

