

LIGHT-DUTY TROLLEY OPERATOR-MODEL ATS

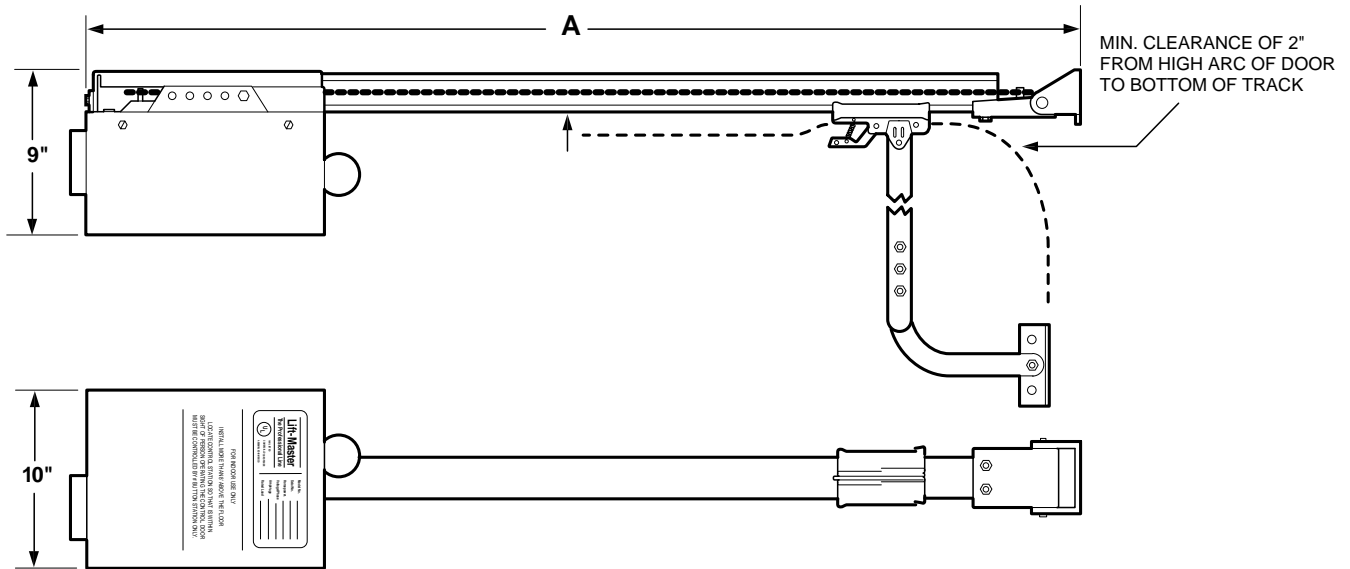

Door Height	8'	10'	12'
A - Dimension	Door Height + 3'-3"	Door Height + 3'-3 "	Door Height + 3'-9"

STANDARD FEATURES

Model Specific:

Work included – The electric operator will be Lift-Master Model ATS as manufactured by The Chamberlain Group, Inc. Related work – Door preparation, miscellaneous or structural metal work, field electrical wiring, wire, conduit, fuses, and disconnect switches are in the scope of work of other divisions or trades.

Product:

Supply Model ATS, light-duty UL and CSA listed, trolley type operator(s) rated 1/2 H.P., 115 Volts, Single Phase.

General:

Provide electric door operator which meets UL 325 regulations for both residential and industrial applications, complete with 1/2 H.P. electric

motor and factory-prewired motor controls, single button open/close/stop control station, UL and CSA listed self-monitoring infrared sensing device which is integral to the operator system and accessories required for proper operation.

Electric Motor:

Motor shall be high starting torque, 1/2 H.P. motor with instant reverse and motor overload protection.

Trolley Track:

Heavy-duty steel "I-Beam" configured trolley track with automatic reconnect trolley in case of manual operation.

Safety:

The operator will include an Automatic Safety Reverse/Automatic Door Stop and non-impact infrared safety device.

Motor Starter, Controls, Enclosures: Motor starter shall be solid state circuitry. Motor starting device shall be enclosed in a NEMA 1 enclosure.

Limit Switches:

Fully adjustable, driven linear type limit switch mechanism shall synchronize the operator with the door.

Execution:

Install the motor operator in accordance with Lift-Master instructions and standards and in compliance with applicable federal, state or local regulations.

Warranty:

Lift-Master Commercial Door Operators and accessories shall be warranted to be free of any defect in materials and workmanship for a period of one year.

Lift-Master
The Professional Line
Commercial Operators

Manufactured by:

The Chamberlain Group, Inc.
845 Larch Avenue • Elmhurst, Illinois 60126
World's Largest Manufacturer of Door Openers

For More Information Call: (800) 323-2276 or (800) 766-1188 Or Fax: (630) 530-6098 or (516) 467-2566